



REVERSIBLE GEARBOX WITH PARALLEL GEARS

ASYNCHRONOUS MOTOR

HOLLOW OR SOLID SHAFT

TECHNICAL FEATURES :

- Asynchronous motor
- Greased lubricated
- Solid or hollow shaft
- Thermal cut out
- 2 direction of rotation
- Class B insulation
- IP44 protection
- S1 service class
- Working Temperature : -20°C to +85°C

OPTIONS AVAILABLE ON DEMAND :

- Inrush or lack of current brake (24V or 230V with diode rectifier) with or without manual unlocking
- Voltages and frequencies on request
- Reinforced motor for more torque
- Torque motor
- Class F insulation
- IP55 protection
- Output shaft according to specifications

COMPLY WITH STANDARDS :

- EN 60335-1
- EN 60034-1

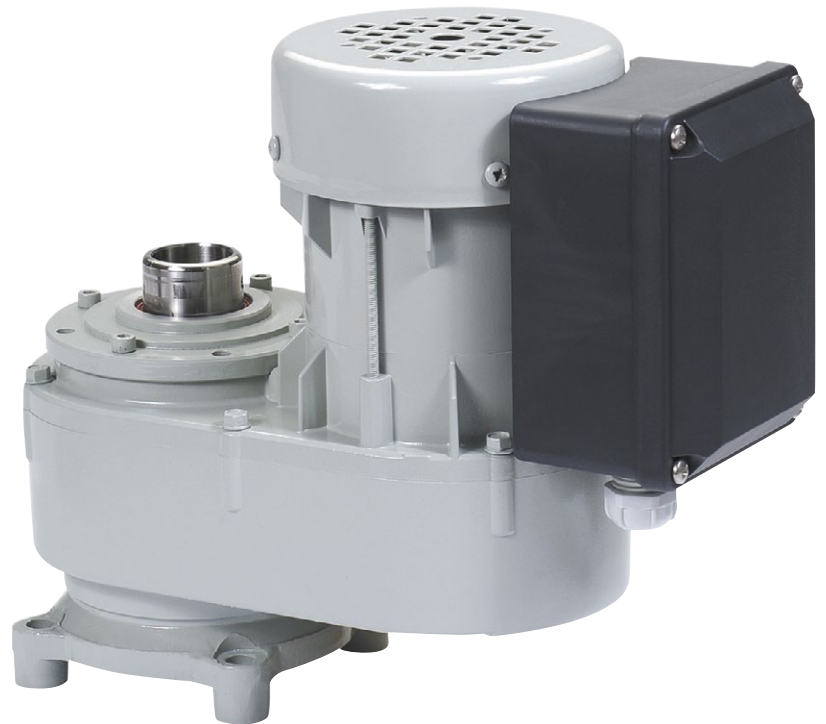

Shaft with keyway

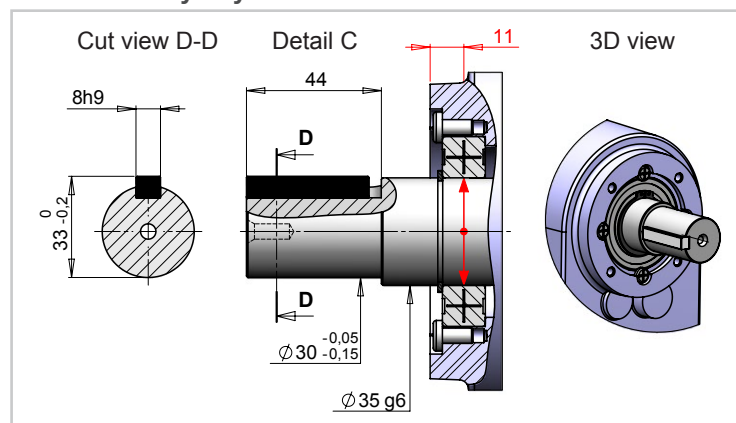

DIMENSIONS

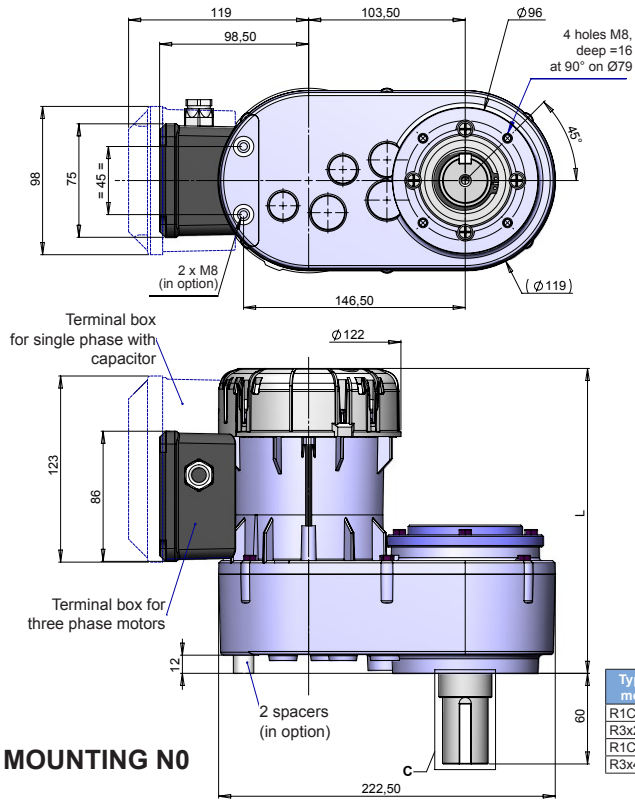

MOUNTING N2

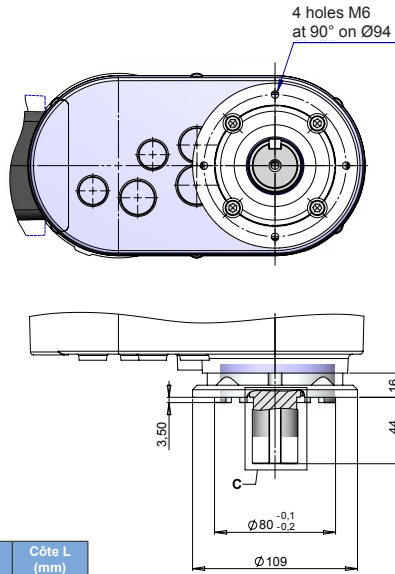

MOUNTING N5

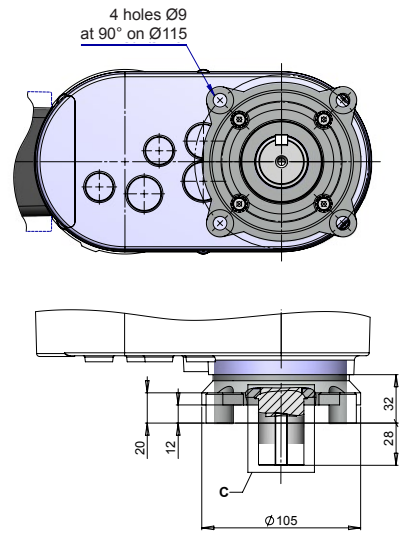

Type de moteur	Côte L (mm)
R1Cx25N	182
R3x25N	182
R1Cx45N	202
R3x45N	202

TECHNICAL FEATURES

Designation and Motor Type	GEARBOX						MOTOR									Weight (kg)	
	Gearbox speed (RPM)	Nominal torque (Nm)	Startup torque (Nm)	Maximum radial load* (N)	Maximum axial load (N)	Gearbox ratio	Output power (watts)	Motor torque (Ncm)	Motor speed (RPM)	Current under 230v (A)	Ia/In	Cd/Cn	Cos φ	Service class	Capacitor (µF)		
Single phase versions	R1C 425 N B	2,2	100	85	2800	1700	1/615	40	28,3	1350	0,55	1,34	0,85	0,99	S1	4	6,1
	R1C 225 N B	4,5	74	76	2670	1600	1/615	51	17,1	2850	0,57	1,73	1,03	0,96	S1	5	6,1
	R1C 245 N B	4,5	100	80	2670	1600	1/615	71	24,2	2800	0,59	2,3	0,8	0,99	S1	5	6,5
	R1C 225 N B	5,1	65	67	2550	1580	1/548	51	17,1	2850	0,57	1,73	1,03	0,96	S1	5	6,1
	R1C 245 N B	5,1	90	72	2550	1580	1/548	71	24,2	2800	0,59	2,3	0,8	0,99	S1	5	6,5
	R1C 225 N B	6,5	51	53	2340	1550	1/429	51	17,1	2850	0,57	1,73	1,03	0,96	S1	5	6,5
	R1C 245 N B	6,5	70	56	2340	1550	1/429	71	24,2	2800	0,59	2,3	0,8	0,99	S1	5	6,5
	R1C 225 N B	7,3	46	47	2200	1500	1/383	51	17,1	2850	0,57	1,73	1,03	0,96	S1	5	6,1
	R1C 245 N B	7,3	65	52	2200	1500	1/383	71	24,2	2800	0,59	2,3	0,8	0,99	S1	5	6,5
	R1C 245 N B	9,5	51	41	2080	1400	1/303	71	24,2	2800	0,59	2,3	0,8	0,99	S1	5	6,5
	R1C 445 N B	10,5	40	24	2000	1300	1/126	59	41,7	1350	0,53	1,53	0,61	0,99	S1	4	6,5
	R1C 245 N B	14	34	27	1840	1200	1/200	71	24,2	2800	0,59	2,3	0,8	0,99	S1	5	6,5
	R1C 245 N B	21	25	20	1600	1020	1/126	71	24,2	2800	0,59	2,3	0,8	0,99	S1	5	6,5
	R1C 245 N B	25	22	18	1500	930	1/112	71	24,2	2800	0,59	2,3	0,8	0,99	S1	5	6,5
	R1C 245 N B	32	17	14	1380	820	1/89	71	24,2	2800	0,59	2,3	0,8	0,99	S1	5	6,5
R1C 245 N B	48	12	10	1220	690	1/59	71	24,2	2800	0,59	2,3	0,8	0,99	S1	5	6,5	
R1C 245 N B	67	8,1	6	1100	580	1/42	71	24,2	2800	0,59	2,3	0,8	0,99	S1	5	6,5	
Three phase versions	R3 425 N B	3,3	80	152	2800	1650	1/429	40	27,3	1400	0,41	2	1,9	0,65	S1	-	6,1
	R3 225 N B	4,5	74	105	2670	1600	1/615	51	17,3	2800	0,37	2,97	1,42	0,7	S1	-	6,1
	R3 245 N B	4,5	100	97	2670	1600	1/615	73	24,8	2800	0,42	3,25	0,97	0,79	S1	-	6,5
	R3 225 N B	5,1	65	92	2550	1580	1/548	51	17,3	2800	0,37	2,97	1,42	0,7	S1	-	6,1
	R3 245 N B	5,1	90	87	2550	1580	1/548	73	24,8	2800	0,42	3,25	0,97	0,79	S1	-	6,5
	R3 225 N B	6,5	51	72	2340	1550	1/429	51	17,3	2800	0,37	2,97	1,42	0,7	S1	-	6,1
	R3 245 N B	6,5	70	68	2340	1550	1/429	73	24,8	2800	0,42	3,25	0,97	0,79	S1	-	6,5
	R3 225 N B	7,3	46	65	2200	1500	1/383	51	17,3	2800	0,37	2,97	1,42	0,7	S1	-	6,1
	R3 245 N B	7,3	65	63	2200	1500	1/383	73	24,8	2800	0,42	3,25	0,97	0,79	S1	-	6,5
	R3 245 N B	9,5	51	49	2080	1400	1/303	73	24,8	2800	0,42	3,25	0,97	0,79	S1	-	6,5
	R3 445 N B	10,5	40	57	2000	1300	1/126	50	35,5	1350	0,4	2,24	1,43	0,67	S1	-	6,5
	R3 245 N B	14	34	33	1840	1200	1/200	73	24,8	2800	0,42	3,25	0,97	0,79	S1	-	6,5
	R3 245 N B	21	25	24	1600	1020	1/126	73	24,8	2800	0,42	3,25	0,97	0,79	S1	-	6,5
	R3 245 N B	25	22	21	1500	930	1/112	73	24,8	2800	0,42	3,25	0,97	0,79	S1	-	6,5
	R3 245 N B	32	17	16	1380	820	1/89	73	24,8	2800	0,42	3,25	0,98	0,79	S1	-	6,5
R3 245 N B	48	12	12	1220	690	1/59	73	24,8	2800	0,42	3,25	0,97	0,79	S1	-	6,5	
R3 245 N B	67	8,1	8	1100	580	1/42	73	24,8	2800	0,42	3,25	0,97	0,79	S1	-	6,5	

* : applied on the bearings (see detail on C shaft)

Reinforced motor version for more torque on request

